

# **TABLE OF CONTENTS**

1. INTRODUCTION.....	1
2. IMPORTANT SAFETY PRECAUTIONS.....	2
3. ASSEMBLING YOUR TREADMILL.....	4
List of Parts.....	4
4. TREADMILL ASSEMBLY.....	5
Pedestal and Handle Assembly.....	5
Display Installation.....	6
Connect to Power.....	7
5. T630 Display.....	8
Display Features.....	8
Display Functions.....	8
Button Functions.....	9
Safety Key.....	11
6. HOW TO USE YOUR T630 TREADMILL.....	12
QUICK START.....	12
WORKOUT SETUP.....	12
OPERATING PROCEDURE WHILE WORKING.....	13
COOL DOWN.....	14
7. PROGRAMS.....	15
USER PARAMETER SETTING.....	17
8. GUIDELINES FOR EXERCISE.....	18
9. ADJUST THE WALK BELT.....	19
10. FLOOR LEVEL ADJUSTMENT.....	21
11. MAIN FUSE FAILURE.....	22
12. ERROR MESSAGE.....	23
13. WIRING SCHEMATIC.....	24



**INTRODUCTION**

Congratulations on purchasing one of the finest pieces of commercial exercise equipment on the market today, the SportsArt T630 Commercial Treadmill. The T630 is designed with the end-user in mind and constructed of high quality materials and designed for years of trouble-free use.

Before using your SportsArt T630 Treadmill, we recommend that you familiarize yourself with this Owner's Manual. Whether you are a first time user of a treadmill or a seasoned "PRO", understanding the correct use of the equipment will enhance your ability to achieve your exercise goals safely and successfully.

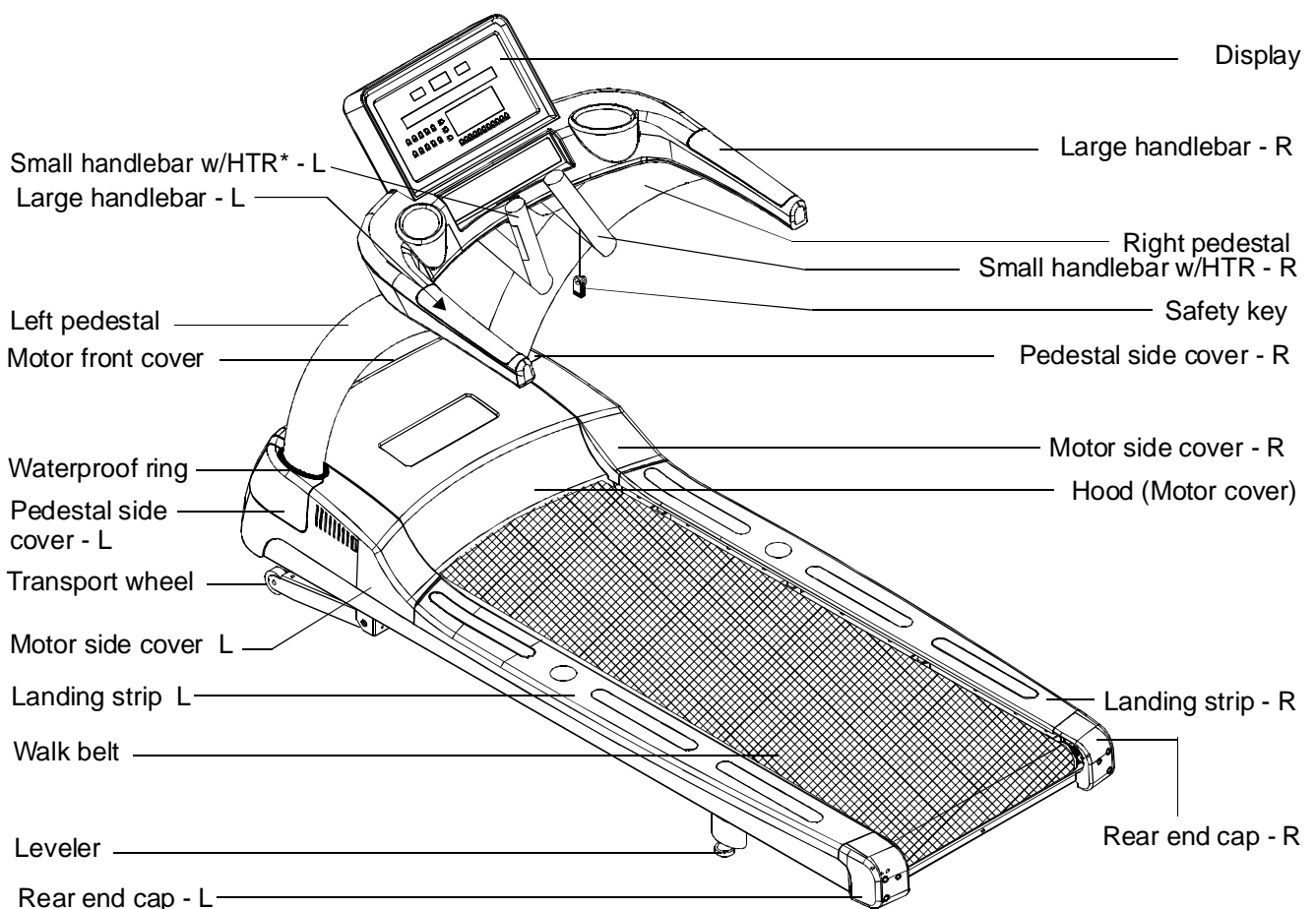

\* HTR = hand touch readout technology

Your SportsArt treadmill was designed and built for optimum safety. However, certain precautions apply whenever you use your treadmill.

Please read the entire manual before assembly and operation. Also, please note the following safety precautions:

## **IMPORTANT SAFETY PRECAUTIONS**

- Please read the instruction carefully and install the treadmill as instructed.
- Assemble and operate the treadmill on a solid, level surface. DO NOT use outdoors or near water.
- Never allow children on or near the treadmill at all times.
- Check the treadmill before every use. Make sure all parts are assembled, and all fasteners are tightened. DO NOT use the treadmill if the unit is disassembled in any way.
- Keep your hands away from moving parts.
- Wear proper workout clothing: DO NOT wear loose clothing. DO NOT wear shoes with leather soles or high heels. Tie all long hair back.
- Be careful when mounting and dismounting the unit.
- The walk belt will not stop immediately if any object becomes caught in the belts or rollers.
- DO NOT use any accessories that aren't specifically recommended by the manufacturer. These might cause injuries or cause the unit to fail.
- Unplug from outlet before servicing or removal of any parts.
- Close supervision is necessary when this treadmill is used by, on, or near children, invalids, or disabled persons.
- Use this treadmill only for its intended use as described in this manual.
- Never operate this treadmill if it has been damaged in any way. If it is not working properly, been dropped or damaged, contact your dealer.
- DO NOT carry this treadmill by power cord or use cord as a handle.
- Keep the power cord away from heated surfaces.

- Keep all air ventilation areas free of blockage.
- Never drop or insert any object into any opening.
- DO NOT operate where aerosol (spray) products are being used or where oxygen is being administered.
- The weight limit for this treadmill is 160 KGS (350 LBS).
- Product performance depends on adequate power supply. Each commercial treadmill requires one 20Amp (for 110v area) or one 10Amp (for 220v area) dedicated circuit for proper operation.

## **CAUTION**

If you feel any pain or abnormal, STOP YOUR WORKOUT and consult your physician immediately. Work within your recommended exercise level. DO NOT work to exhaustion.

Before beginning any exercise program, you should consult with your doctor. It is recommended that you undergo a complete physical examination.

DO NOT stand on the belt when starting. Straddle the belt with your feet on the right and left landing strips.

**Always use the safety cord when operating the treadmill.**

**DANGER** - To reduce the risk of electric shock, always unplug this treadmill from the electrical outlet immediately after using and before cleaning.

Improper connection of the equipment-grounding connector can result in a risk of electric shock. Check with a qualified electrical or service person if you are in doubt as to whether the treadmill is properly grounded. DO NOT modify the plug provided with T650 treadmill, if it doesn't fit the outlet; get the proper outlet installed by a qualified technician.

## **ASSEMBLING YOUR TREADMILL**

Thank you for purchasing our product. Even though we go to great efforts to ensure the quality of each product, occasional errors and/or omissions do occur. In any event should you find the product to be defective or missing a part, please contact your local dealer.

Please read this owner's manual and follow the instructions.

**Caution:** Two persons are recommended to assemble the treadmill. To avoid back strain and to ensure safety to the unit and yourself, we suggest you avoid lifting the running bed assembly from box. Instead drop the sides of the box and slide the treadmill from the container rather than lifting it.

**IMPORTANT:** The packaging is specifically designed for the machine delivery, please have it properly kept, in case the machine needs to be shipped in the future.

### **List of Parts**

Before assembling the treadmill, please make sure all parts below are present.

1. Metal stem of one screwdriver
2. Plastic handle of one screwdriver
3. One L-shaped Allen wrench (M6)
4. One T-shaped Allen wrench (M5)
5. One T-shaped Allen wrench (M6)
6. One 15A (110V) / 10A (220V) fuse
7. One T-shaped Allen wrench (M4)
8. One double open end wrench (22/24)
9. Two screw head covers (M8)
10. Two decorative caps (M8)

Some parts may get mixed amongst packaging material during shipping. Please locate all the parts before you discard the packaging material. Thoroughly read the assembly instructions before you begin.

# TREADMILL ASSEMBLY

## PEDESTAL AND HANDLE ASSEMBLY

STEP 1. First, remove the side plates of the pedestals (both left and right). Then thread the data cable through the right pedestal. Secure the pedestals by fastening the bolts with washers as shown. At this point, do NOT tighten these bolts securely. (See Fig. 1.)

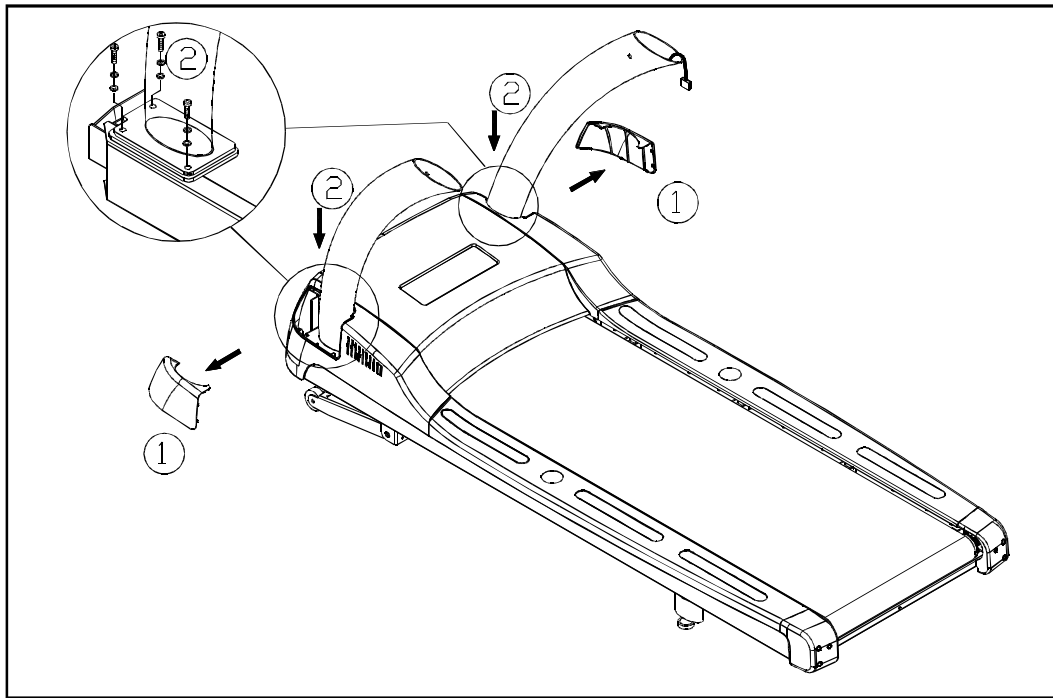

Fig.1

STEP 2. Connect the data cable. Then hold the handlebars onto the pedestals. (See Fig. 2.)

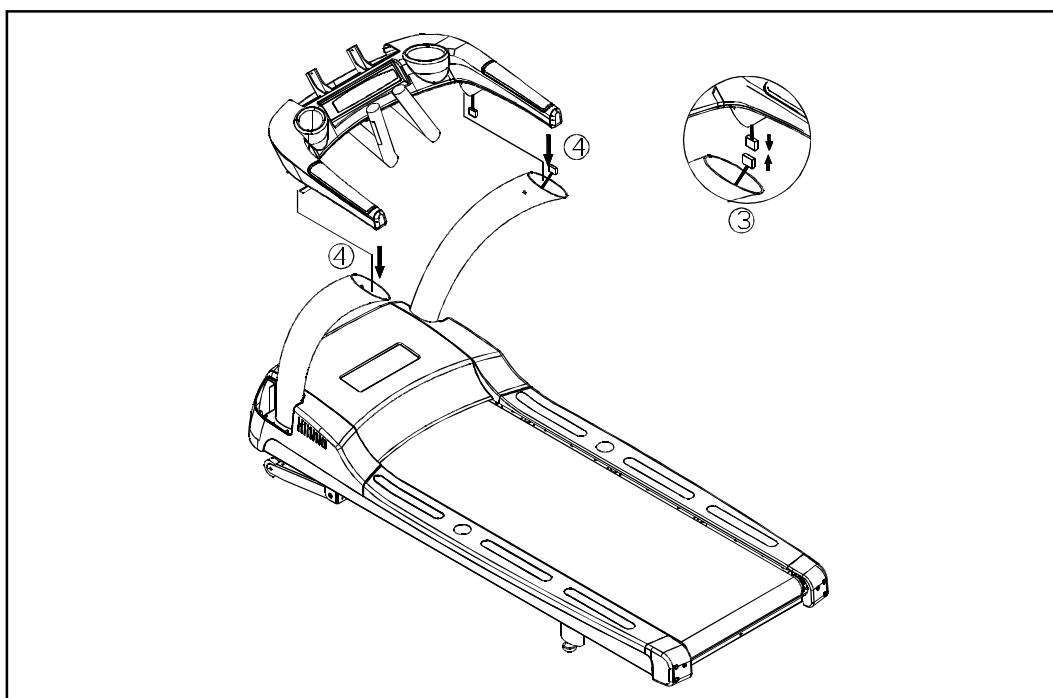

Fig.2

STEP 3. Secure the handlebars by fastening the bolts with washers (A: arc washers; B: flat washers) as shown. Then put the decorative covers in place. After that, firmly tighten the bolts to secure the pedestals and secure the pedestal side covers (both left and right) in place. (See Fig. 3.)

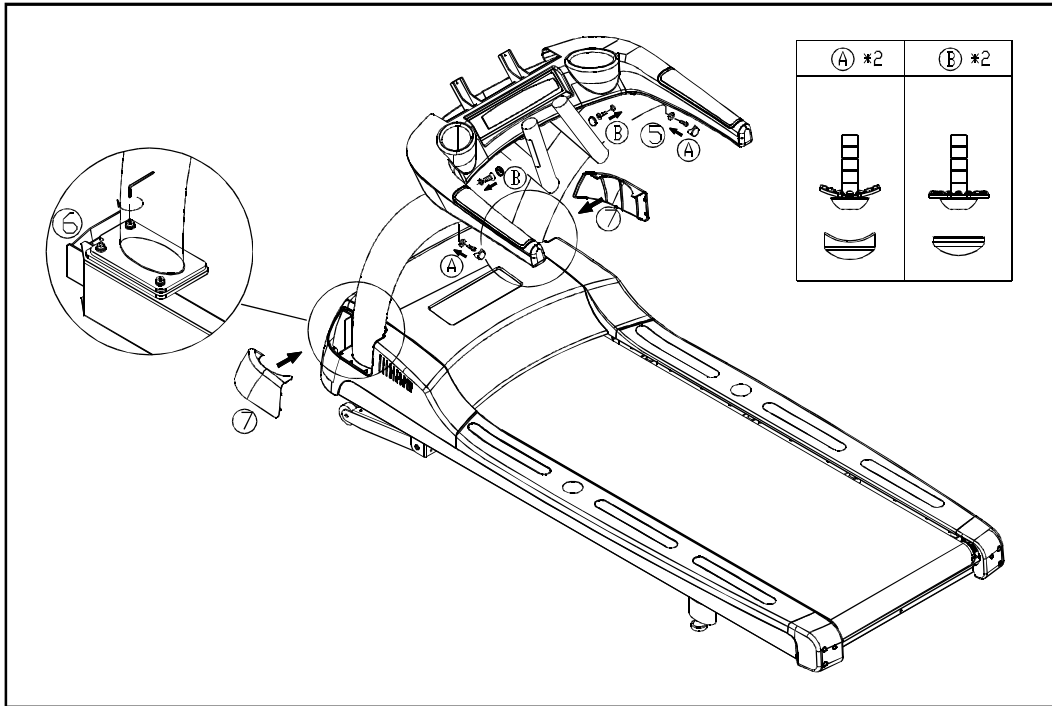

Fig.3

## **DISPLAY INSTALLATION**

Connect the data cables as shown. Hold the display into position. Secure the display with bolts (M5) provided. (See Fig. 4.)

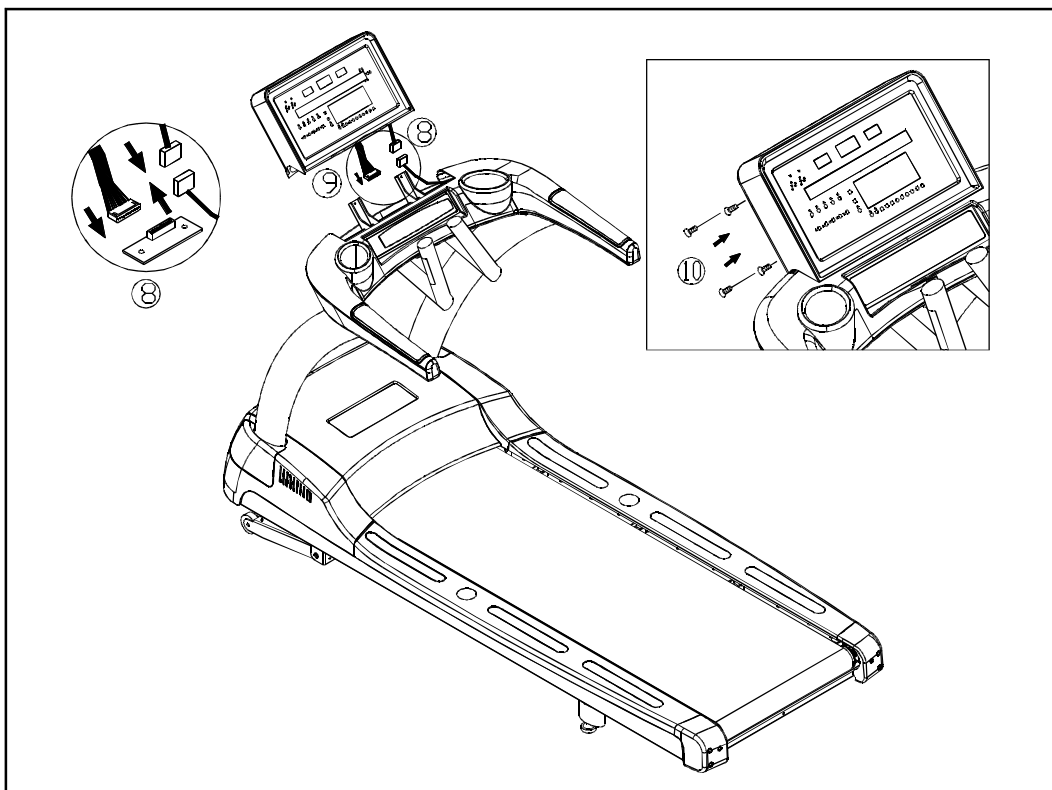

Fig.4

## **CONNECT TO POWER**

Connect the power cable as indicated in Fig. 5, and secure it by tightening the screws.

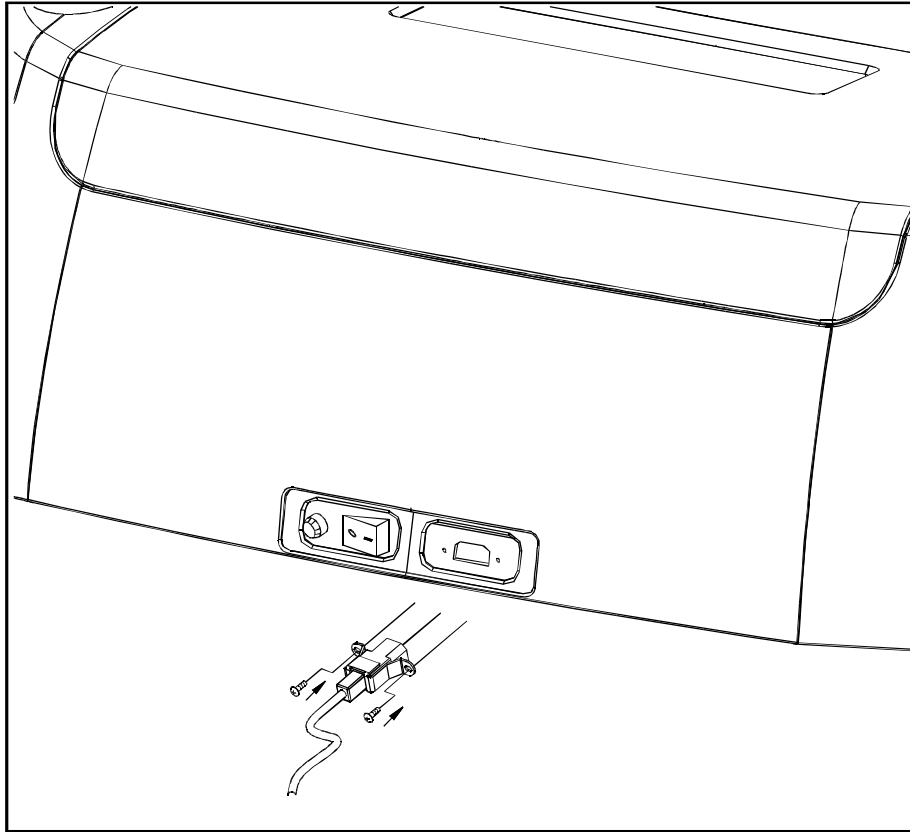
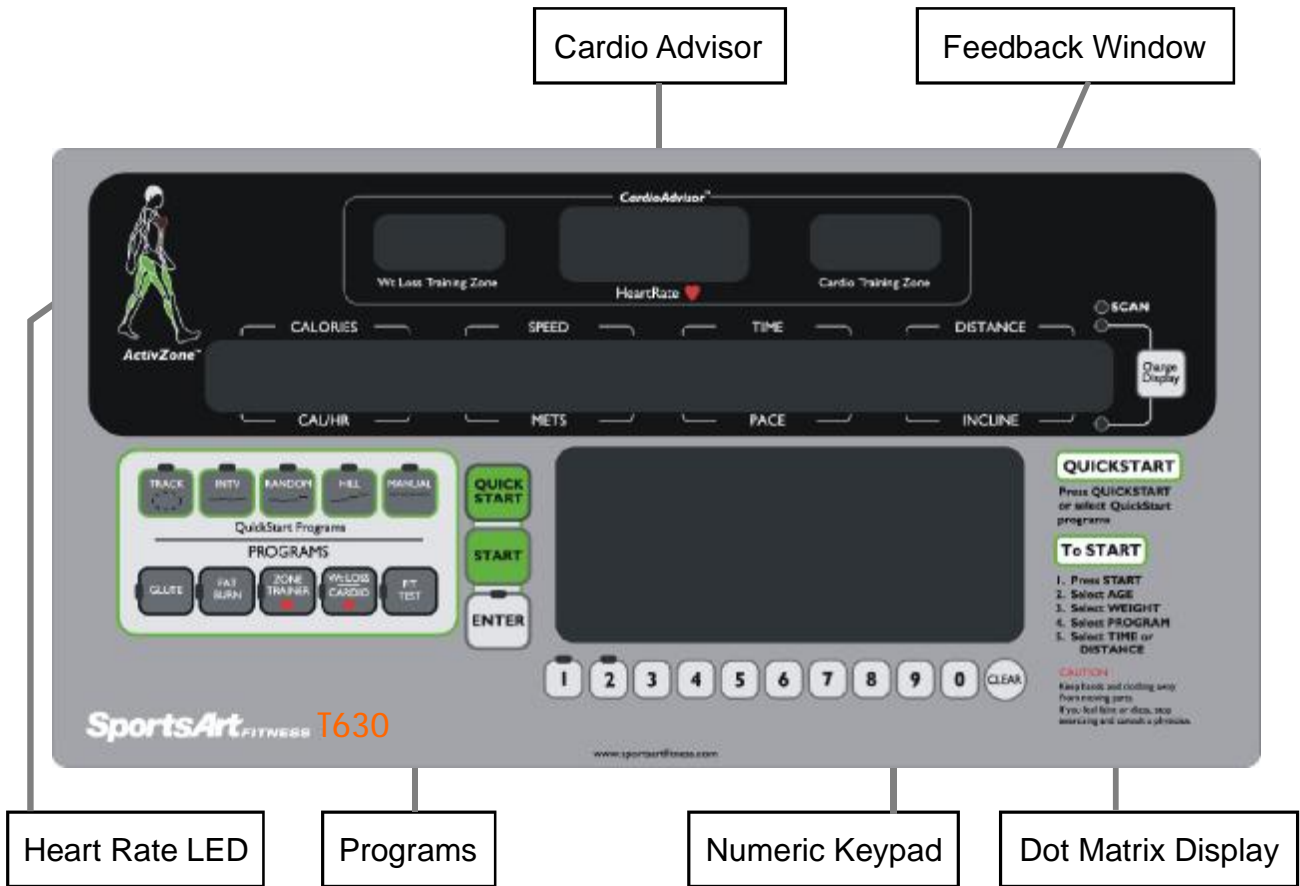

Fig.5



# T630 Display

## A. Display Features



## B. Display Functions

1. SPEED: 0.1 to 12.0 MPH or 0.2 to 20.0 KPH in 0.1 increments
2. INCLINE: 0 to 15%, in 0.5% increments
3. TIME: 0:00 to 99:59
4. DISTANCE: 0.01 to 9999 Km/Mile
5. CALORIES: Total calories burnt, 0.0 to 9999 KCAL

6. CAL/Hr: Calories burnt per hour, 0.0 to 999.9 KCAL
7. METS (Metabolic burn rate): 0.00 to 99.00
8. PACE: 1/SPEED
9. PROGRAM: MANUAL, HILL (HILL1, HILL2, HILL3), RANDOM, INTERVAL (1:1, 1:2, 2:2), TRACK (TRACK 5K, TRACK 10K), GLUTE, FAT BURN, ZONE TRAINER, WT LOSS/CARDIO and FIT TEST (BRUCE, GERKIN).
10. Dot Matrix Display: Displays program profiles and information.

## **C. Button Functions**

1. QUICK START  
Quick Start will bypass User, Age, Weight inputs and Program selection. Time will count up.
2. START  
Press START at the startup banner to set up user information (age, weight, etc.).
3. CHANGE DISPLAY  
While working out, press CHANGE DISPLAY to see different information. The LED of the corresponding information will appear. When the SCAN LED lights up, the 14-segment display will automatically scan, showing various information (CALORIES SPEED TIME DISTANCE → CAL/HR METS PACE INCLINE...) every six seconds. Press CHANGE DISPLAY again to see different information.
4. ENTER  
After entering all parameters, press ENTER to confirm your choice.
5. MANUAL  
Press this button to start MANUAL mode.
6. HILL  
There are three kinds of HILLS: HILL 1, HILL 2, and HILL 3.
7. RANDOM  
Press RANDOM to generate different courses.
8. INTV  
There are three kinds of INTERVALs: 1:1, 1:2, and 2:2.  
For example, in 1:2, 1 = one minute of rest; 2 = two minutes of work.
9. TRACK  
There are two kinds of TRACKs: TRACK 5K and TRACK 10K. 5K means the workout goal distance is 5 Km, while 10K means 10Km.

10. WT LOSS/CARDIO

Press to start the heart rate control modes - Wt Loss & Cardio. The weight loss program keeps the user's heart rate at 65% of maximum (i.e.  $(220-AGE)*0.65$ ) to provide an optimal weight loss workout, while the cardio program keeps the user's heart rate at 80% of maximum (i.e.  $(220-AGE)*0.8$ ) to provide an optimal cardio workout.

11. GLUTE

This program is specifically designed to exercise the gluteus muscle group of the body; 30- and 45-minute durations are available in these incline-based programs.

12. FAT BURN

Twenty levels are available for selection.

13. ZONE TRAINER

When you are in another course and would like to maintain a specific heart rate, press the Zone Trainer button and the program changes to a Heart Rate Control (HRC) program. The incline and/or speed will automatically change to maintain your selected heart rate.

14. FIT TEST

FIT TEST offers two types of fitness tests: Bruce and Gerkin.

15. Numeric Keypad (0 to 9)

The numeric keypad can replace the function of ▲/▼ buttons. Simply enter numbers (0 to 9) on the numeric keypad rather than pressing ▲/▼ buttons.

16. ▲/▼

Press these buttons to adjust functions up or down. To increase or decrease adjustments rapidly, hold either button down.

17. CLEAR

Pressing this button clears inputted data.

18. INCLINE ▲/▼

Press INCLINE▲/▼ to increase or decrease the incline in 0.5% increments. Keep the button pressed to enable more rapid adjustments.

19. SPEED ▲/▼

Press SPEED▲/▼ to increase or decrease the walk belt speed. Speed adjusts ▲/▼ in 0.1MPH/KPH increments. To increase or decrease adjustments rapidly, hold either button down.

20. STOP/HOLD TO RESET

a. While exercising:

(1) If you pressed QUICK START to start exercising, press STOP to stop. Then the startup banner appears on the display.

(2) If you entered user information to start exercising, press STOP to stop the treadmill and enter pause mode.

- b. Under any status:  
Hold this button to reset to the startup screen.

#### **D. Safety Key**

1. The safety key must be in place for the treadmill to operate. This safety device is intended to stop the treadmill should a user stumble and fall.
2. If the safety key is not in place, the message "SAFETY KEY" appears on the display to remind the user to put the safety key in place.

# **HOW TO USE YOUR T630 TREADMILL**

## **1. QUICK START**

If you select QUICK START, "TREAD STARTING" appears on the display and the walk belt moves at 0.1MPH/0.2KPH, after which the speed can be modified. The user information default is 165lbs/75kgs.

## **2. WORKOUT SETUP**

Input user information to obtain more accurate information on caloric burn, heart rate control (range is generated by age entered), and to accumulate total use time, distance, and calories burned (PROGRAM/AGE/WEIGHT).

### **A. INPUT USER'S AGE & WEIGHT**

(1) AGE: From 10 to 99 (default value: 35).

- a. Press ▲/▼ or the numeric keypad to select your age.
- b. Press ENTER to confirm your choice.

(2) WEIGHT: From 50 to 400 LB / 20 to 140 KG (default value: 165 LB / 75 KG).

- a. Press ▲/▼ or the numeric keypad to select your weight.
- b. Press ENTER to confirm your choice.

### **B. PROGRAM SETTING PROCEDURE**

(1) When "MANUAL" is selected, the 14-segment display will show "MANUAL". Press ENTER to confirm your choice. Then, the 14-segment display will show "TIME-1 DIST-2". Press the numeric keypad (1 or 2) to select time or distance, or press ENTER to select TIME.

(2) When "HILL" is selected, the 14-segment display will show "HILL 1". Press HILL to select HILL 1, HILL 2, or HILL 3. After that, press ENTER to confirm your choice. Then, the 14-segment display will show "TIME-1 DIST-2". Press the numeric keypad (1 or 2) to select time or distance, or press ENTER to select TIME.

(3) When "RANDOM" is selected, the 14-segment display will show "RANDOM". Press ENTER to confirm your choice. Then, the 14-segment display will show "TIME-1 DIST-2". Press the numeric keypad (1 or 2) to select time or distance, or press ENTER to select TIME.

(4) When "INTV" is selected, the 14-segment display will show "INTV 1:1". Press INTV to select INTV 1:1, INTV 1:2, or INTV 2:2. After that, press ENTER to confirm your choice. Then, the 14-segment display will show "TIME-1 DIST-2". Press the numeric keypad (1 or 2) to select time or distance, or press ENTER to select TIME.

(5) When "TRACK" is selected, the 14-segment display will show "TRACK". Press more times to view TRACK → TRACK 5K → TRACK 10K →... In "TRACK", press ENTER to confirm your choice. If you selected TRACK 5K or TRACK 10K, the exercise course begins immediately. If you selected TRACK, the 14-segment display will show "TIME-1 DIST-2". Press the numeric keypad (1 or 2) to select time or distance, or press ENTER to select TIME.

- (6) When "FIT TEST" is selected, the 14-segment display will show "FIT TEST". Press ENTER to confirm your choice. Then, the 14-segment display will show "BRUCE-1 GERKIN-2". Press the numeric keypad (1 or 2) to select either program, or press ENTER to select BRUCE.
- (7) When "WT LOSS/CARDIO" is selected, the 14-segment display will show "CARDIO". Press CARDIO/WT LOSS to select CARDIO or WT LOSS programs.
  - a. Press ENTER to confirm your choice.
  - b. The 14-segment display will show "TIME-30". Press the numeric keypad (0 to 9) or INCLINE ▲/▼ to select time, then press ENTER to confirm your choice.
  - c. The 14-segment display will show "ENTER MAX SPEED". ENTER the desired speed by pressing the numeric keypad. Then press ENTER to confirm your choice.
- (8) When "FAT BURN" is selected, the 14-segment display will show "FAT BURN". Press ENTER to confirm your choice. Then, the 14-segment display will show "TIME-1 DIST-2".
  - a. Press the numeric keypad (1 or 2) to select time or distance, or press ENTER to select TIME.
  - b. After inputting all the data, press ENTER to confirm your choice.
  - c. Press the numeric keypad (0 to 9) or INCLINE ▲/▼ to select LEVEL (1 to 20).
  - d. Press ENTER to confirm your choice.
- (9) When "GLUTE" is selected, the 14-segment display will show "GLUTE 30". Press GLUTE to select GLUTE 30 or GLUTE 45. After that, press ENTER to confirm your choice. Then, the 14-segment display will show "TIME-1 DIST-2". Press the numeric keypad (1 or 2) to select time or distance, or press ENTER to select TIME.

After inputting age and weight, selecting any of the above nine exercise programs, and inputting your workout goals, press SPEED▲ to start working out.

### 3. OPERATING PROCEDURE WHILE EXERCISING

- A. Press QUICK START or input user information to start working out. The 14-segment display will show "TREAD STARTING". Meanwhile, the dot matrix display will display "3→2→1", and then the treadmill will start operating.
- B. The following information is displayed:
  - (1) The 14-segment display shows one of two rows of workout information: CALORIES SPEED TIME DISTANCE ↔ CAL/HR METS PACE INCLINE. Press CHANGE DISPLAY to alternate between the two rows of workout information.
  - (2) Wt Loss Training Zone & Cardio Training Zone: Users of different ages will see different target heart rates. The target heart rate is based on user age.

C. Users can adjust settings while working out:

Programs can be changed during a workout. Press the corresponding program button to change programs. WORKOUT GOAL (TIME/DISTANCE) counts up continuously.

Remarks:

- (1) After QUICK START is used to activate the treadmill, MANUAL, HILL, RANDOM, INTV, or TRACK programs can be accessed.
- (2) After START is used to activate the treadmill, all programs, except Zone Trainer, can be accessed.

#### **4. COOL DOWN**

Upon achieving the WORKOUT GOAL (TIME/DISTANCE), the display shows "ACCU DATA" (accumulative data for your workout). After displaying the accumulative time/distance/calories/average heart rate, the treadmill will automatically enter a COOL DOWN program ("COOL DOWN" will appear). Walk belt speed will gradually slow to 0.0MPH/KPH in 2 minutes; incline will decline to 0% incline, and the COOL DOWN time will be two minutes. Time counts down to "0:00". The treadmill stops and then "SELECT PROGRAM" appears.

## **PROGRAMS**

### 1. MANUAL & TRACK

One lap is equal to 400 meters (0.25 mile).

### 2. HILL

There are three kinds of HILLS (HILL 1, HILL 2, and HILL 3). Press HILL to switch to a different hill course.

### 3. RANDOM

The random program includes an infinite number of programs. Continue to press this button until you find a course to your liking.

### 4. INTERVAL (1:1, 1:2, 2:2)

INTV (INTERVAL) courses are based on "work" and "rest" periods. The time, incline and speed of each period can differ. The time ratio of rest to work can be 1:1, 1:2, or 2:2. (Rest is represented by the first number; work is represented by the second number. For example, 1:2 means 1 minute of rest & 2 minutes of work.)

A. Press INTERVAL while exercising to switch to a different INTERVAL mode.

B. While exercising, you can change the speed and incline of any interval at the beginning of the interval. That change will also apply to the corresponding interval thereafter.

### 5. FIT TEST

This program provides two types of physical fitness tests: BRUCE & GERKIN. When pressing FIT TEST, the 14-segment display will show "BRUCE-1 GERKIN-2". Press the numeric keypad (1 or 2) to select either program, or press ENTER to start exercising under the Bruce test. Once a fitness test has started, you must finish the test before other exercise programs can be activated. After completing the test, the 14-segment display will show "END OF FIT TEST" "YOUR SCORE = ???". (In this manual, "???" is used to represent your score number. A number will appear on the actual display.) The highest score is 100, while the lowest is 0.

### 6. WT LOSS & CARDIO

These programs employ what is called Heart Rate Control (HRC) technology to adjust speed and/or incline to maintain a specific target heart rate. Heart rate control programs are designed to provide optimal efficiency in reaching your exercise goals.

#### A. Target heart rates:

(1) WT LOSS = 65% Heart Rate Control:  $(220 - \text{AGE}) \times 65\%$

(2) CARDIO = 80% Heart Rate Control:  $(220 - \text{AGE}) \times 80\%$

#### B. HRC (Heart Rate Control) mode:

Before starting to exercise, select the maximum speed. The 14-segment display will show "ENTER MAX SPEED". Press ▲/▼ or use the numeric keypad (0 to 9) to input a maximum speed. Press ENTER to confirm your choice.



- a. The initial speed is 0.1MPH/0.2KPH. The treadmill speeds up to the selected maximum speed.
  - b. The maximum speed can be adjusted during exercise. Press SPEED ▲/▼ or use the numeric keypad (0 to 9) to adjust the maximum speed. The 14-segment display will show "ENTER MAX SPEED". The setting window will display the previously selected maximum speed.
- C. At the start of a workout, or anytime when the heart rate signal is not received, the 14-segment display will show "NO HEART RATE READING, PLEASE CHECK TRANSMITTER". This is just a reminder to the user. SPEED or INCLINE still will increase automatically.

## 7. ZONE TRAINER

The Zone Trainer program can only be selected from other courses during your workout. While exercising in another, non-HRC program, press the Zone Trainer program button. The original workout becomes a heart rate control program. The HR range is 84-200.

- A. In Zone Trainer mode, you cannot immediately access GLUTE, FAT BURN, WT LOSS/CARDIO, or FIT TEST mode, but you can access TRACK, INTV, RANDOM, HILL, and MANUAL modes.
- B. Once you go to this program, you are prompted to continue your workout to reach the goal you set up previously. The speed and/or incline will be automatically operated by the display. When you complete your workout goal, you will directly go into a COOL DOWN program.

## 8. FAT BURN

- A. There are twenty levels for selection.
- B. Press INCLINE ▲/▼ or the numeric keypad (0 to 9) to change the LEVEL while exercising.

## 9. GLUTE

The glute program is specifically designed to exercise the gluteus muscles. Press to choose between 30- and 45-minute programs in this incline-based exercise mode.

## USER PARAMETER SETTING

User parameters determine basic operating features, such as distance units, of the treadmill. To change these parameters, at the banner display, hold the CHANGE DISPLAY button for three seconds.

1. Set up MPH/KPH. The 14-segment display will show the current status ( "UNIT - MPH" or "UNIT - KPH"). Press ▲/▼ to change MPH or KPH. Press ENTER to confirm your choice.
2. The total accumulative distance appears as follows.

D	I	S	T	-	?	?	?	?	?	?	K	M		
---	---	---	---	---	---	---	---	---	---	---	---	---	--	--

Press ENTER to display the total time.

3. The total accumulative time is shown as below.

T	I	M	E	-	?	?	?	?	?	?	H	O	U	R	
---	---	---	---	---	---	---	---	---	---	---	---	---	---	---	--

Press ENTER to display the version of the software.

4. Display the software version:
  - A. The 14-segment display will show the control board version: "CTL XXXXX - XX". Press ENTER to continue.
  - B. The 14-segment display will show the drive board version: "DRV XXXXX - XX". Press ENTER to return to the banner display.

# **GUIDELINES FOR EXERCISE**

## **How hard should I exercise?**

Studies show that to achieve the benefits of aerobic exercise, it is necessary to work within your training zone. Your training zone depends on your age and level of fitness.

The above chart indicates the recommended Heart Rate training zones (darkened area of the chart). These figures are calculated by taking 220 minus your age, and calculating 80% for your maximum and 65% for the minimum heart rate for aerobic exercise.

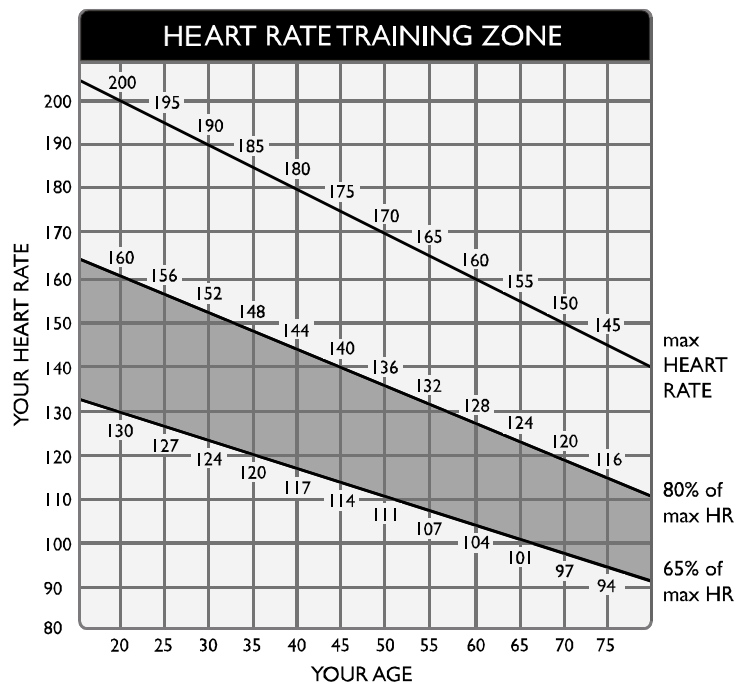

## **CAUTION:**

**Heart Rate training zones are approximations. Always check with your physicians to learn what appropriate heart rate level is best for your fitness level.**

## **How long should I exercise?**

The duration of your exercise session depends on your fitness level. In general, it is recommended that you maintain your heart rate in the training zone for at least 15 to 20 minutes to realize an aerobic benefit. Beginners should always start slowly and bring their workout sessions up to 20 minutes or more. As your fitness level increases, you will be able to maintain your heart rate in the training zone for longer periods: Usually between 20 and 30 minutes.

When first starting your workout, use the first several minutes to warm up, then slowly increase your workload to bring your heart rate into your specific training zone. At the end of your workout, gradually decrease your workload, then exercise lightly as a "cool down".

## **How often should I exercise?**

Research indicates to achieve the greatest benefits, should be performed 3-5 times a week. It is important to allow sufficient time, at least 24 hours, for your body to recover after exercise.

## **ADJUSTING THE WALK BELT**

For optimum performance, the walk belt must track in the center of the deck. Failure to align the belt properly could cause the belt to tear or fray, which is not covered under the warranty.

Caution: To avoid injury, special care must be taken when adjusting the walk belt. Be careful to keep your fingers, clothes and other objects clear of the belt and rollers. The treadmill will not stop immediately if objects become caught in the belt or rollers. Do not allow anyone to stand on the walk belt during this procedure.

Please follow the belt adjustment procedure listed below:

1. Determine belt position in relation to the belt alignment gauge on the walk deck. The red mark on the gauge indicates misalignment. The belt should center in the middle of the green area.
2. If the belt is in the red mark on either side of the deck, follow the steps below to align the walk belt.
3. Turn off the unit.
4. If the belt is too far left, use the hex Allen wrench to turn the left adjustment bolt at the rear of the treadmill clockwise 1/4 turn. Then turn the right adjustment bolt counterclockwise 1/4 turn. Turn on the treadmill. Press the SPEED button to increase the speed until the speed reaches 2.0 MPH/3.2KPH on the display. Inspect belt alignment.
5. If the belt has not returned to the green zone, repeat with another 1/4 turn on both sides until the belt has returned to the middle of the green area. Do not turn the walk belt adjustment bolt more than 1/4 turn at a time. If the belt is on the edge of the green color, turn the adjustment bolt less than 1/4 turn at a time to center the belt.
6. If the belt is too far right, turn the right adjustment bolt clockwise 1/4 turn, then turn the left adjustment bolt counterclockwise 1/4 turn. Turn on the treadmill. Press the SPEED button to increase the speed until the speed reaches 2.0 MPH/3.2KPH on the display. Inspect belt alignment.
7. If the belt has not returned to the green zone, repeat with another 1/4 turn on both sides until the belt has returned to the middle of the green area. Do not turn the walk belt adjustment bolt more than 1/4 turn at a time. If the belt is on the edge of the green color, turn the adjustment bolt less than 1/4 turn at a time to center the belt.

8. Let the treadmill run at least 30 seconds, while checking the position of the belt in the color gauge. When the belt is back in the green "safety zone", you can continue your regular use of the treadmill. Slowly increase the speed of the unit to 5.5 MPH (9 KPH), and let it run for at least 45 seconds. Make sure that the belt tracks properly.
9. When you are using the treadmill, if you feel a pause when your foot hits the belt, the belt is too loose. Stop the machine. Adjust both rear roller bolts clockwise 1/2 turn at a time. Try the machine again, then check the result. If necessary, give both adjustment bolts another slight turn.
10. Do not over-tighten the belt. Over-tightening the walk belt can shorten the life of the unit. Please see Fig. 6-2 and 6-3.
11. Periodically inspect belt tracking and tightness to ensure optimum performance of your treadmill. To check the correct tension of the belt, hold the belt in the middle, and lift up about 30 mm (1 1/8") or 3 kg (6.6 pounds) of force (see Fig. 6, 6-1, 6-2).

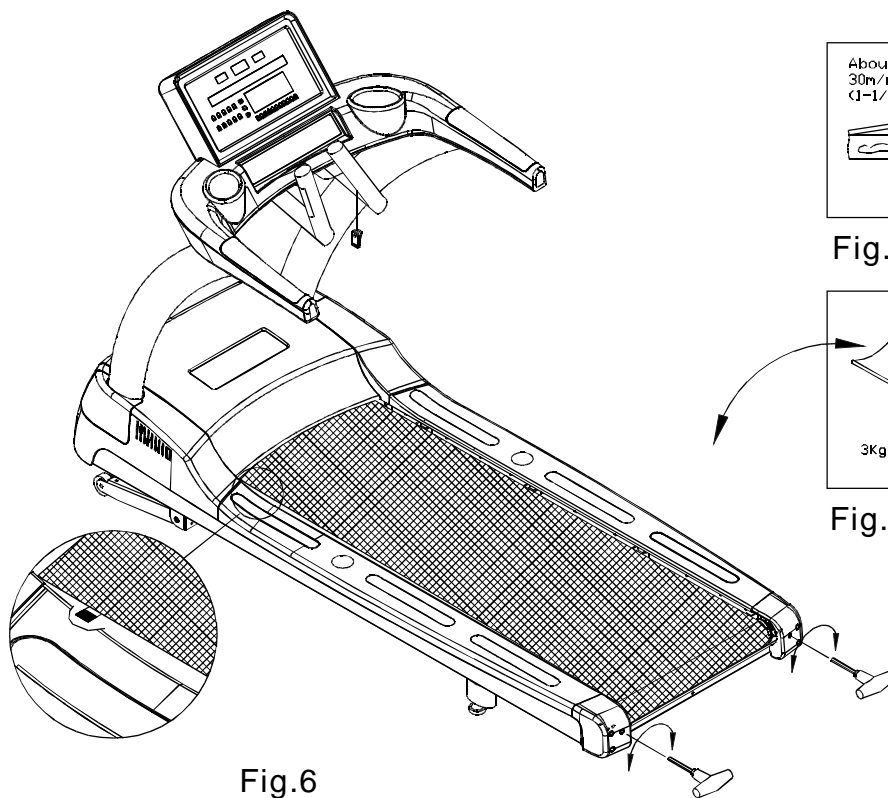

Fig.6

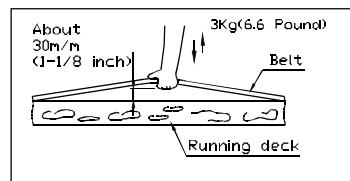

Fig.6-1

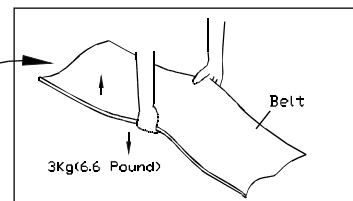

Fig.6-2

## **FLOOR LEVEL ADJUSTMENT**

Level the treadmill as follows. Use the DOUBLE OPEN ENDED WRENCH to turn the levelers on the rear of the treadmill. Raise or lower the floor levelers to steady the treadmill. Once it is level, secure the position by tightening the leveler nuts up against the unit frame. (See Fig. 7)

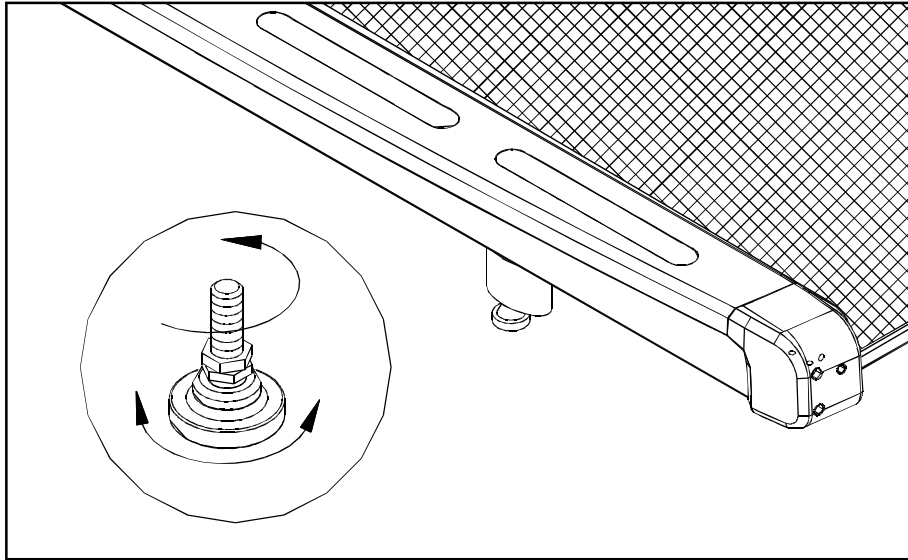

Fig.7

## **MAIN FUSE FAILURE**

If the display remains dark after turning on the unit, the fuse may be damaged and need to be replaced.

**CAUTION:** MAKE SURE THE TREADMILL POWER PLUG IS REMOVED FROM OUTLET BEFORE REPLACING THE FUSE.

Main power fuse holder located at bottom of the machine, near the on/off switch. (See Fig. 8-1) To remove the main fuse, push the fuse holder toward the machine and turn it counterclockwise, then pull out the fuse holder. Remove the fuse from the holder. Insert a new fuse of the appropriate type into the fuse holder and insert it into the unit. Turn the fuse holder clockwise to secure the fuse in place. (See Fig. 8-2 to Fig. 8-4.)

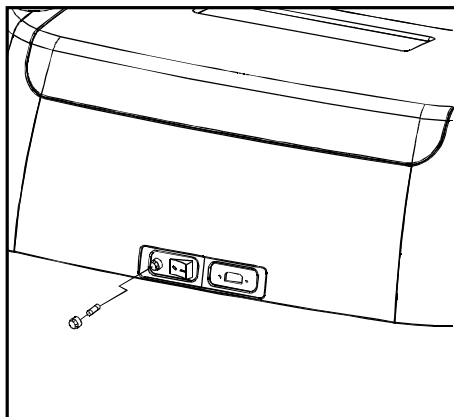

Fig.8-1

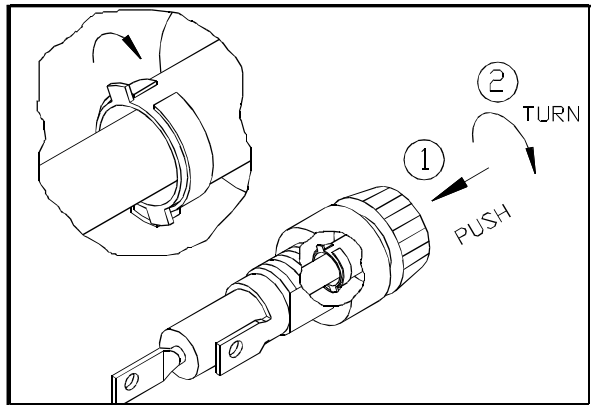

Fig.8-2

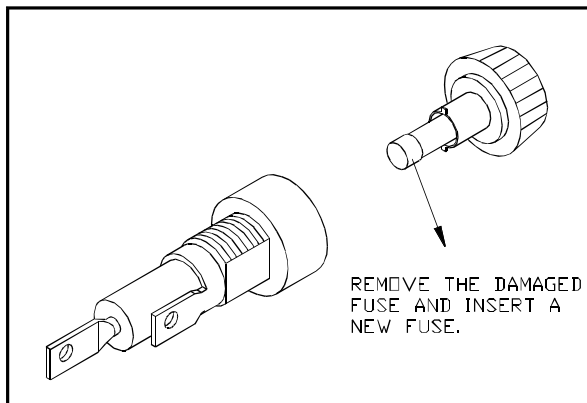

Fig.8-3

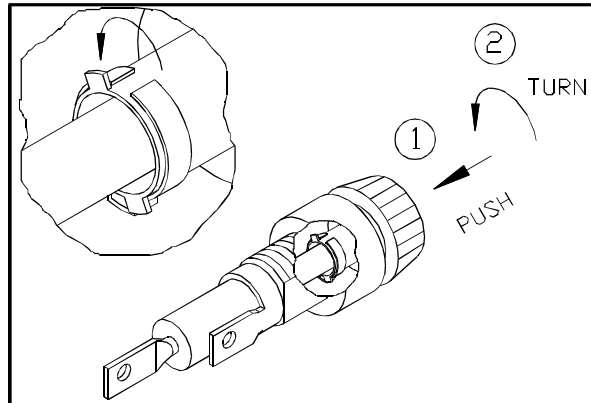

Fig.8-4

If the unit does not work after changing the fuse, please contact your authorized SportsArt Fitness service technician for more information.

## ERROR MESSAGES

1. 

SERVICE REQUIRED TREADMILL SHUTTING DOWN STOPPING
---

The motor is overheated. Please turn off and turn on again to reuse the treads.

2. Display format:

						E	R	R	X						
--	--	--	--	--	--	---	---	---	---	--	--	--	--	--	--

ERR1: The optical switch mounted on the motor is not receiving the signal reflected from the tachometer wheel. Please contact your dealer.

ERR3: The user is running faster than the belt. Please turn off the treads and try normal use again.

ERR7: The elevation motor has a calibration issue. Please contact your dealer.



# Wiring Schematic:

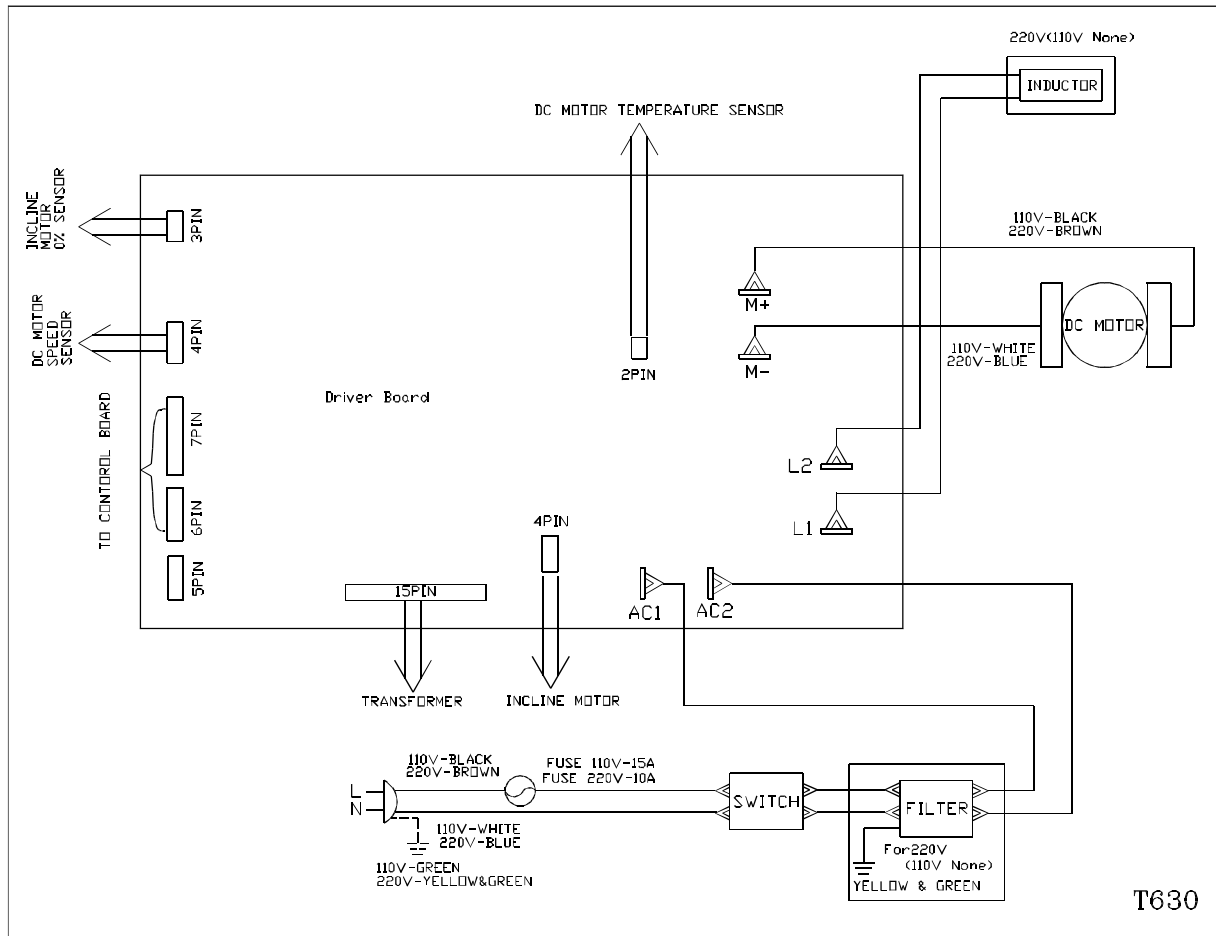

**Your Authorized Distributor**